

KLT-N6MF-IMX274 V1.0

8.3MP Sony IMX274 MIPI Interface M12 Fixed Focus Camera Module



Front View



Back View

Specifications

Camera Module No.	KLT-N6MF-IMX274 V1.0
Resolution	8.3MP
Image Sensor	IMX274
Sensor Type	1/2.5"
Pixel Size	1.62 um x 1.62 um
EFL	3.60 mm
F.NO	2.00
Pixel	3840 x 2160
View Angle	130.0°(DFOV) 100.0°(HFOV) 59.0°(VFOV)
Lens Dimensions	13.65 x 13.65 x 22.52 mm
Module Size	40.00 x 22.00 mm
Module Type	Fixed Focus
Interface	MIPI
Auto Focus VCM Driver IC	None
Lens Model	KLT-LENS-MJ3621A
Lens Type	650nm IR Cut
Operating Temperature	-30°C to +75°C
Mating Connector	DF30FC-30DS-0.4V



KLT-N6MF-IMX274 V1.0

8.3MP Sony IMX274 MIPI Interface M12 Fixed Focus Camera Module



Top View



Side View

www.KaiLapTech.com

www.KaiLapTech.com



Bottom View



Mating Connector

Version Mark	Information	Date
V1.0	PD First Version	04-09-2019

RoHS	
PIN	SIGNAL
1	XCE
2	DGND
3	DVDD1.2V
4	D0VDD1.8V
5	XHS
6	XVS
7	AVDD2.8V
8	AGND
9	SDA
10	SCL
11	DGND
12	XCLR
13	DGND
14	INCK
15	DGND
16	DMO4P
17	DMO4N
18	DGND
19	DMO3P
20	DMO3N
21	DGND
22	DMO2P
23	DMO2N
24	DGND
25	DMCKP
26	DMCKN
27	DGND
28	DMO1P
29	DMO1N
30	DGND

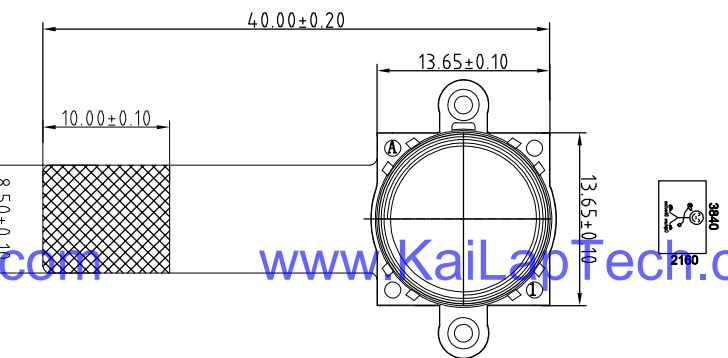

TOP VIEW

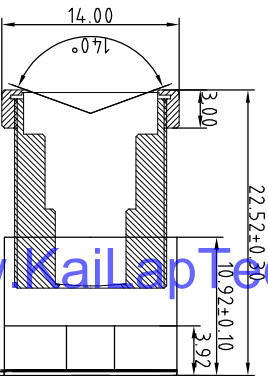

SIDE VIEW

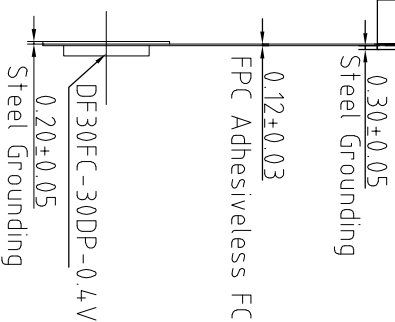

BOTTOM VIEW

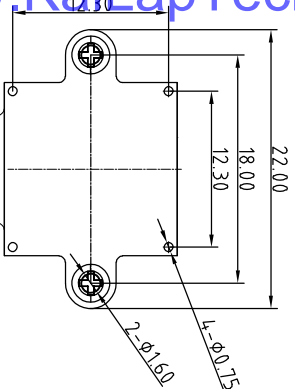

Parameters:

1. Sensor specification:

Image Sensor: IMX274LQAC-C
 Pixel: 1.62umx1.62um
 Lens Type: 1/2.5
 Important Voltage Description: DVDD1.2V (external power supply);

2. Lens specification:

FOV: 140°
 F/No: 2.0
 TV distortion: <25%
 Focal length: 3.6mm
 Composition: 4G +IRFILTER
 IR Cut Coating: 650nm±10nm@50%

Kai Lap Technologies Group Ltd

Designed By

Kevin

Model Name:

KLT-N6MF-IMX274 V1.0

Checked By

Aouly Yan

Projection Type:

Third Angle

Unit: mm

Material: -----

Scale: 1:1

Sheet: 1 of 1

Version: 1/0

3

3

2

2

1

1

A

B

C

D

E



Lens Model: KLT-LENS-MJ3621A

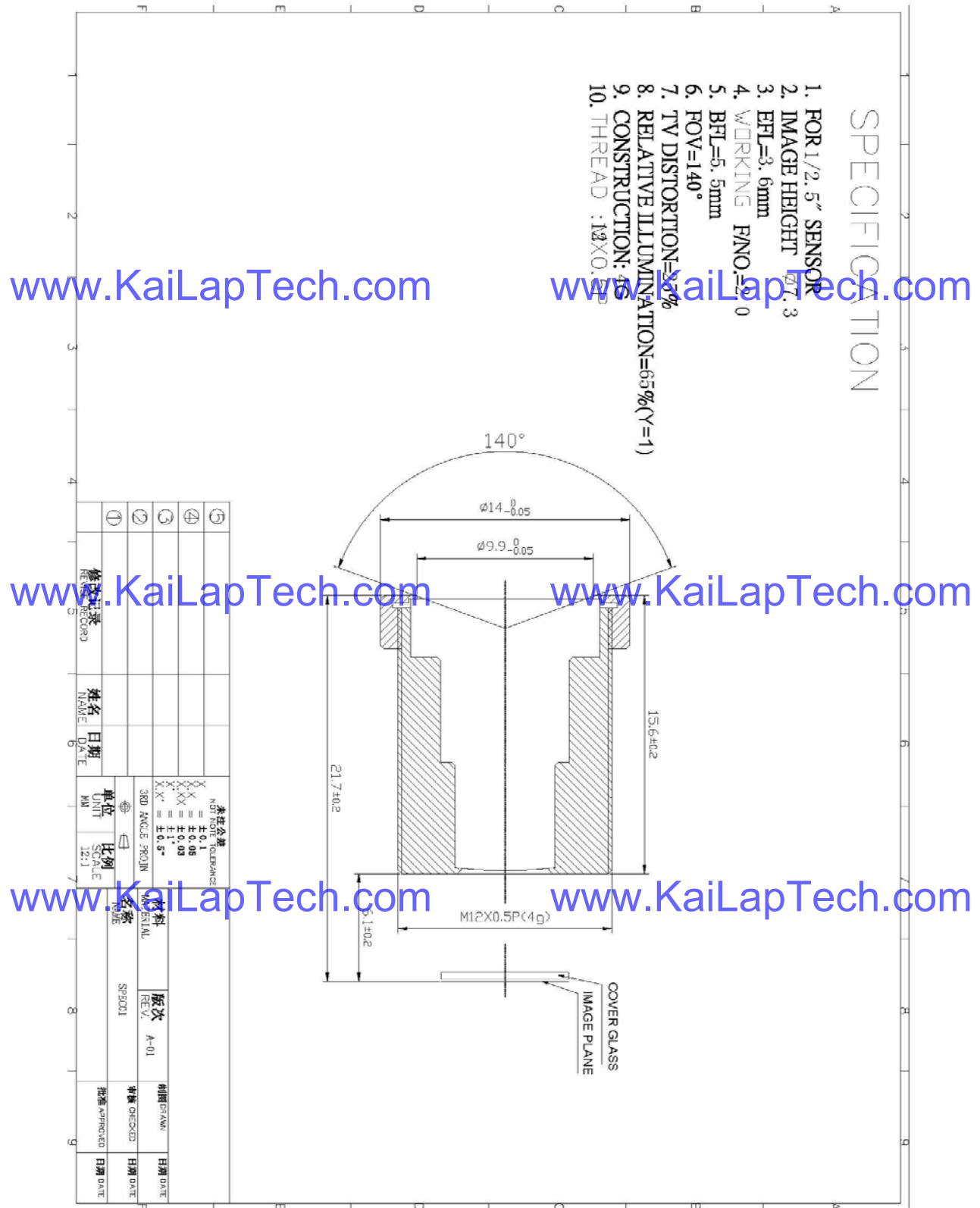

0.4 mm Pitch, 0.9 mm Height, Board-to-Board / Board-to-FPC Connectors

DF30 Series

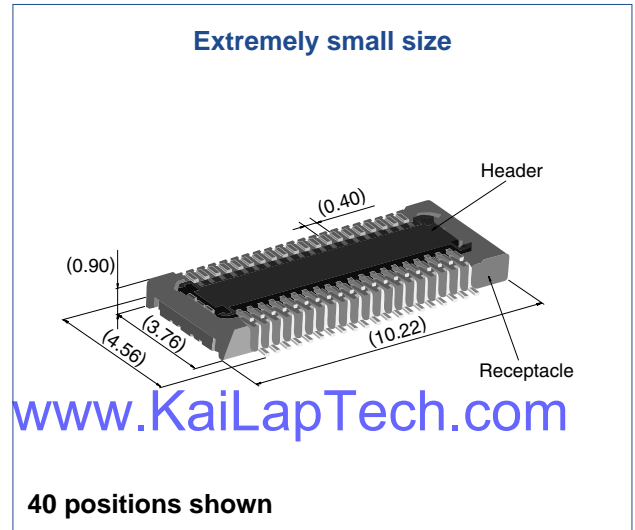
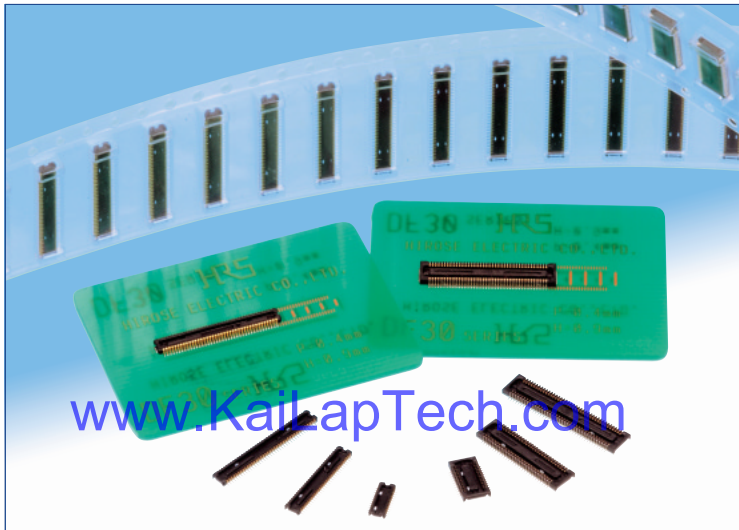

Overview

Continuous miniaturization and increased component density on PCB created demand for extremely low profile connectors. This series is addition of a new extremely low profile connectors to Hirose's wide range of high reliability board-to-board/board-to-FPC connection solutions.

Features

- 1. Contact reliability**
Concentration of the contact's normal forces at the single point assures good contact wipe and electrical reliability, while confirming the fully mated condition with a definite tactile click.
- 2. Self alignment**
Recognizing the difficulties of mating extremely small connectors in limited spaces the connectors will self align in horizontal axis within 0.3 mm.
- 3. Automatic board placement**
Packaged on tape-and-reel the plug and headers have sufficiently large flat areas to allow pick-up with vacuum nozzles of automatic placement equipment.
- 4. Variety of contact positions and styles**
Available in standard contact positions of: 20, 22, 24, 30, 34, 40, 50, 60, 70 and 80 with and without metal fittings. Addition of metal fittings does not affect external dimensions of the connectors. Smaller contact positions are also available.
- 5. Support for continuity test connector**
Connectors which have increased insertion and removal durability are available for continuity tests. Contact your Hirose sales representative for details.

Applications

Cellular phones, PDA's, mobile computers, digital cameras, digital video cameras, and other devices demanding high reliability connections in extremely limited spaces.

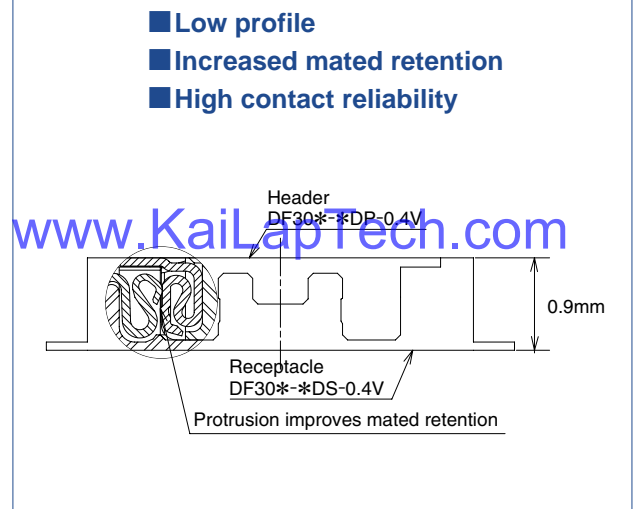

Product Specifications

Rating	Rated current 0.3A Rated voltage 30V AC	Operating temperature range : -35°C to 85°C (Note 1) Operating humidity range : Relative humidity 20% to 80%	Storage temperature range -10°C to 60°C (Note 2) Storage humidity range Relative humidity 40% to 70% (Note 2)
--------	--	---	--

Item	Specification	Conditions
1. Insulation resistance	50 MΩ min.	100V DC
2. Withstanding voltage	No flashover or insulation breakdown.	100V AC / one minute
3. Contact resistance	100 mΩ max.	100 mA
4. Vibration	No electrical discontinuity of 1 μs or more	Frequency: 10 to 55 Hz, single amplitude of 0.75mm, 2 hours, 3 axis
5. Humidity	Contact resistance: 100 mΩ max. Insulation resistance: 25 MΩ min.	96 hours at temperature of 40°C±2°C and RH of 90% to 95%
6. Temperature cycle	Contact resistance: 100 mΩ max. Insulation resistance: 50 MΩ min.	Temperature: -55°C→+5°C to +35°C→+85°C→+5°C to +35°C Duration: 30→10→30→10(Minutes) 5 cycles
7. Durability (insertions/withdrawals)	Contact resistance: 100 mΩ max.	50 cycles (Connector for conductivity tests: 500 cycles)
8. Resistance to soldering heat	No deformation of components affecting performance.	Reflow: At the recommended temperature profile Manual soldering: 300°C for 3 seconds

Note 1: Includes temperature rise caused by current flow.

Note 2: The term "storage" refers to products stored for long period of time prior to mounting and use. Operating temperature range and humidity range covers non-conducting condition of installed connectors in storage, shipment or during transportation.

Materials and Finishes

Connectors	Component	Material	Finish	Remarks
Receptacles and Headers	Insulator	LCP	Color : Black	UL94V-0
	Contacts	Phosphor bronze	Gold plated	
	Metal fittings	Phosphor bronze	Tin-copper plated	

Ordering information

Receptacles and Headers

DF30 FC - * DS - 0.4 V (**)

1 2 3 4 5 6 7

① Series name: DF30	⑤ Contact pitch: 0.4 mm
② Configuration FB: With metal fittings, without bosses FC: Without metal fittings, without bosses CJ: Connector for conductivity tests	⑥ Termination section V: Straight SMT
③ Number of positions: 20, 22, 24, 30, 34, 40, 50, 60, 70, 80	⑦ Packaging (81): Embossed tape packaging (5,000 pieces per reel) (82): Embossed tape packaging (1,000 pieces per reel)
④ Connector type DS: Double row receptacle DP: Double row header	

■ Receptacles (without metal fittings)

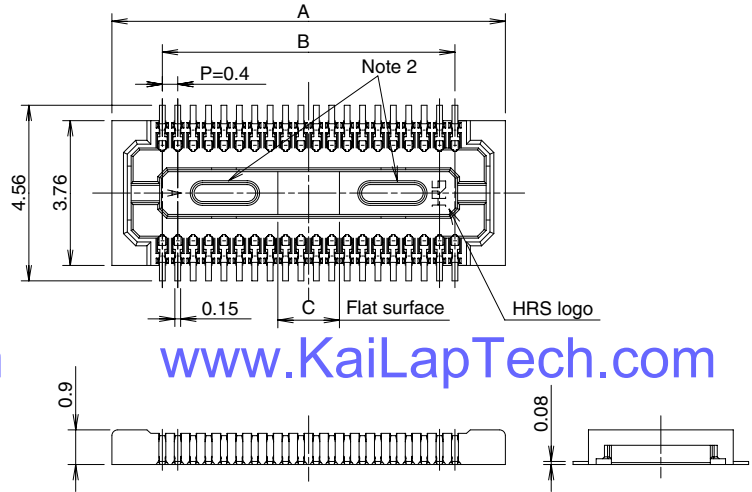
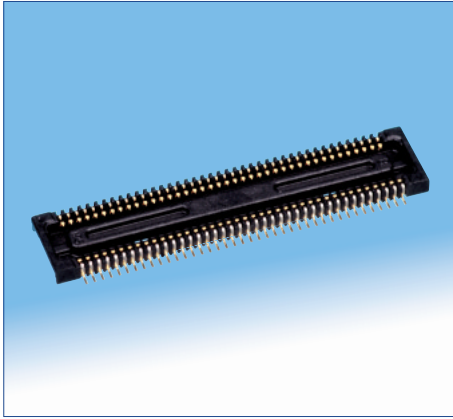

www.KaiLapTech.com

www.KaiLapTech.com

◆ Recommended PCB mounting pattern

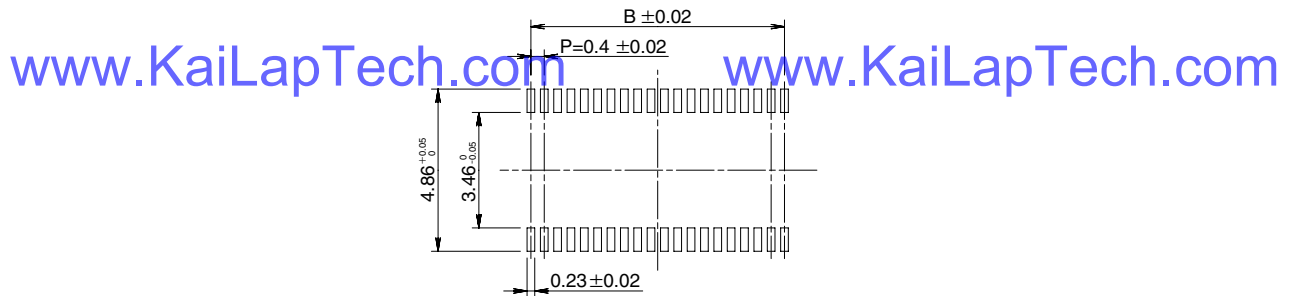

Recommended solder paste thickness: 120 μm

www.KaiLapTech.com [Specification number] -**, (**)
 (81): Embossed tape packaging (5 000 pieces per reel) www.KaiLapTech.com

* Tolerances non- accumulative.

Unit: mm

Part Number	CL No.	Number of contacts	A	B	C
DF30FC-20DS-0.4V(**)	CL684-1109-8-**	20	6.22	3.6	1.2
DF30FC-22DS-0.4V(**)	CL684-1110-7-**	22	6.62	4.0	1.2
DF30FC-24DS-0.4V(**)	CL684-1111-0-**	24	7.02	4.4	1.2
DF30FC-30DS-0.4V(**)	CL684-1112-2-**	30	8.22	5.6	1.2
DF30FC-34DS-0.4V(**)	CL684-1113-5-**	34	9.02	6.4	1.36
DF30FC-40DS-0.4V(**)	CL684-1078-6-**	40	10.22	7.6	1.6
DF30FC-50DS-0.4V(**)	CL684-1114-8-**	50	12.22	9.6	2.0
DF30FC-60DS-0.4V(**)	CL684-1082-3-**	60	14.22	11.6	2.4
DF30FC-70DS-0.4V(**)	CL684-1115-0-**	70	16.22	13.6	2.8
DF30FC-80DS-0.4V(**)	CL684-1116-3-**	80	18.22	15.6	3.2

Note 1: Order by number of reels.

Note 2: Receptacles with 24 or fewer contacts positions will not have recessed areas.

IMX274LQC

Diagonal 7.20 mm (Type 1/2.5) Approx. 8.51M-Effective Pixel
Color CMOS Image Sensor

16:9 Aspect Ratio CMOS Image Sensor Capable of 4K (3840 × 2160) Output for Industrial Applications

Sony has commercialized the "IMX274LQC" Type 1/2.5 (16:9) back-illuminated CMOS image sensor with approximately 8.51M effective pixels for the expanding 4K market.

The IMX274LQC is capable of 4K (3840 × 2160) output at 60 frames/s in ADC 10-bit mode. In addition, the DOL (Digital Overlap)-type HDR (High Dynamic Range) function is

supported at 30 frames/s, realizing 4K video imaging with a wide dynamic range. The IMX274LQC has lower power consumption and is smaller than the existing 4K support CMOS image sensor (IMX172LQT), and the interface supports Sub-LVDS and MIPI CSI-2, enabling use in security camera and industrial applications.

- High-speed video imaging function
- Versatile interface
- DOL-HDR function
- Compact device size

Exmor R

*Exmor R is a trademark of Sony Corporation. The Exmor R is a Sony's CMOS image sensor with significantly enhanced imaging characteristics including sensitivity and low noise by changing fundamental structure of Exmor™ pixel adopted column parallel A/D converter to back-illuminated type.

STARVIS

*STARVIS is a trademark of Sony Corporation. The STARVIS is back-illuminated pixel technology for CMOS image sensors for surveillance camera applications. It features a sensitivity of 2000 mV or more per 1 μm² (color product, when imaging with a 706 cd/m² light source, F0.6 μm²s accumulation equivalent), and realizes high picture quality in the visible-light and near infrared light regions.

High-speed video imaging function

The IMX274LQC realizes 4K (3840 × 2160) all-pixel scan at 30 frames/s in ADC 12-bit mode, and at the high frame rate output of 60 frames/s in ADC 10-bit mode, making it the ideal CMOS image sensor for expanding 4K market applications. The IMX274LQC also realizes Full HD (1920 × 1080) output at 60 frames/s in ADC 12-bit mode (mode 1) and 120 frames/s

in ADC 10-bit mode (mode 2), enabling high-speed video imaging. In addition, various other readout methods are also supported, and diverse drive modes can be selected (Table-3).

Use of a lower frame rate makes it possible to reduce power consumption.

www.KaiLapTech.com

www.KaiLapTech.com

Versatile interface

The IMX274LQC is equipped with two types of output interface (Sub-LVDS, MIPI CSI-2) to meet diverse needs. Both interfaces are capable of 4K 60 frames/s (ADC 10-bit) output, so the

interface can be selected in accordance with the DSP and system used (Table-1).

DOL-HDR function

The IMX274LQC is Sony's first CMOS image sensor to support a DOL-type HDR function for a 4K angle of view. This makes it possible to shoot 4K video with an expanded dynamic

range. The modes that support the DOL function are 4K (3840 × 2160) ADC 10-bit 30 frames/s and Full HD (1920 × 1080) ADC 10-bit 60 frames/s (Table-3).

Compact device size

The IMX274LQC realizes a compact package size of 10.70 mm (H) × 8.50 mm (V) × 1.62 mm (t). This reduced camera

size expands the range of potential security camera and industrial applications.

<Table 1> Device Structure

Item		IMX274LQC
Output image size		Diagonal 7.20 mm (Type 1 / 2.5) aspect ratio 16:9
Number of effective pixels		3864 (H) × 2202 (V) approx. 8.51M pixels
Unit cell size		1.62 μm (H) × 1.62 μm (V)
Optical blacks	Horizontal	Front: 0 pixels, rear: 0 pixels
	Vertical	Front: 16 pixels, rear: 0 pixels
Input drive frequency		12 MHz / 24 MHz / 36 MHz / 72 MHz (Sub-LVDS) 6 MHz / 12 MHz / 18 MHz / 24 MHz (MIPI CSI-2)
Interface		Sub-LVDS (576 Mbps / ch, Max.10 ch) *1 MIPI CSI-2 (1.440 Gbps / Lane) *1
Package		92-pin LGA
Supply voltage V _{DD} (Typ.)		2.8 V / 1.8 V / 1.2 V

*1 Sensor slave mode when using Sub-LVDS and sensor master mode when using MIPI.

<Table 2> Image Sensor Characteristics

Item	Value	Remarks
Sensitivity (F5.6)	Typ. 237 mV	1/30s accumulation
Saturation signal	Min. 630 mV	T _J = 60 °C

<Table 3> Basic Drive Mode

Drive mode	Recommended number of recording pixels	Frame rate [frame/s]	ADC[bit]
All-pixel scan (12 bit)	3840 (H) × 2160 (V)	29.97	12
All-pixel scan (10 bit)	3840 (H) × 2160 (V)	59.94	10
Mode 1*2 (12 bit)	1920 (H) × 1080 (V)	59.94	12
Mode 2*2 (10 bit)	1920 (H) × 1080 (V)	119.88	10
Mode 3*2 (10 bit)	1920 (H) × 1080 (V)	29.97	10
Mode 4*2	1280 (H) × 720 (V)	119.88	10
Mode 5*2	1280 (H) × 540 (V)	239.76	10

Drive mode	Recommended number of recording pixels	Frame rate [frame/s]	ADC[bit]
All-pixel scan (10 bit) DOL*1	3840 (H) × 2160 (V)	29.97	10
Mode 6 (10 bit) DOL*1*2	1920 (H) × 1080 (V)	59.94	10

*1 There are restrictions on the storage time setting values when using DOL.

*2 With vertical addition

*Sony reserves the right to change products and specifications without prior notice.



Camera Module Pinout Definition Reference Chart

OmniVision	Sony	Samsung	On-Semi	Aptina	Himax	GalaxyCore	PixArt	SmartSens	Sensors
Pin Signal		Description							
DGND GND		ground for digital circuit							
AGND		ground for analog circuit							
PCLK DCK		DVP PCLK output							
XCLR PWDN XSHUTDOWN STANDBY		power down active high with internal pull-down resistor							
MCLK XVCLK XCLK INCK		system input clock							
RESET RST		reset active low with internal pull-up resistor							
NC NULL		no connect							
SDA SIO_D SIOD		SCCB data							
SCL SIO_C SIOC		SCCB input clock							
VSYNC XVS FSYNC		DVP VSYNC output							
HREF XHS		DVP HREF output							
DOVDD		power for I/O circuit							
AFVDD		power for VCM circuit							
AVDD		power for analog circuit							
DVDD		power for digital circuit							
STROBE FSTROBE		strobe output							
FSIN		synchronize the VSYNC signal from the other sensor							
SID		SCCB last bit ID input							
ILPWM		mechanical shutter output indicator							
FREQ		frame exposure / mechanical shutter							
GPIO		general purpose inputs							
SLASEL		I2C slave address select							
AFEN		CEN chip enable active high on VCM driver IC							
MIPI Interface									
MDN0 DN0 MD0N DATA_N DMO1N		MIPI 1st data lane negative output							
MDP0 DP0 MD0P DATA_P DMO1P		MIPI 1st data lane positive output							
MDN1 DN1 MD1N DATA2_N DMO2N		MIPI 2nd data lane negative output							
MDP1 DP1 MD1P DATA2_P DMO2P		MIPI 2nd data lane positive output							
MDN2 DN2 MD2N DATA3_N DMO3N		MIPI 3rd data lane negative output							
MDP2 DP2 MD2P DATA3_P DMO3P		MIPI 3rd data lane positive output							
MDN3 DN3 MD3N DATA4_N DMO4N		MIPI 4th data lane negative output							
MDP3 DP3 MD3P DATA4_P DMO4P		MIPI 4th data lane positive output							
MCN CLKN CLK_N DCKN		MIPI clock negative output							
MCP CLKP MCP CLK_P DCKN		MIPI clock positive output							
DVP Parallel Interface									
D0 DO0 Y0		DVP data output port 0							
D1 DO1 Y1		DVP data output port 1							
D2 DO2 Y2		DVP data output port 2							
D3 DO3 Y3		DVP data output port 3							
D4 DO4 Y4		DVP data output port 4							
D5 DO5 Y5		DVP data output port 5							
D6 DO6 Y6		DVP data output port 6							
D7 DO7 Y7		DVP data output port 7							
D8 DO8 Y8		DVP data output port 8							
D9 DO9 Y9		DVP data output port 9							
D10 DO10 Y10		DVP data output port 10							
D11 DO11 Y11		DVP data output port 11							



your **BEST** camera module partner

Cameras Applications



www.KaiLapTech.com



www.KaiLapTech.com



www.KaiLapTech.com

www.KaiLapTech.com



www.KaiLapTech.com



www.KaiLapTech.com





Camera Reliability Test

Reliability Inspection Item			Testing Method	Acceptance Criteria
Category	Item			
Environmental	Storage Temperature	High 60°C 96 Hours	Temperature Chamber	No Abnormal Situation
		Low -20°C 96 Hours	Temperature Chamber	No Abnormal Situation
	Operation Temperature	High 60°C 24 Hours	Temperature Chamber	No Abnormal Situation
		Low -20°C 24 Hours	Temperature Chamber	No Abnormal Situation
	Humidity	60°C 80% 24 Hours	Temperature Chamber	No Abnormal Situation
	Thermal Shock	High 60°C 0.5 Hours Low -20°C 0.5 Hours Cycling in 24 Hours	Temperature Chamber	No Abnormal Situation
Physical	Drop Test (Free Falling)	Without Package 60cm	10 Times on Wood Floor	Electrically Functional
		With Package 60cm	10 Times on Wood Floor	Electrically Functional
	Vibration Test	50Hz X-Axis 2mm 30min	Vibration Table	Electrically Functional
		50Hz Y-Axis 2mm 30min	Vibration Table	Electrically Functional
		50Hz Z-Axis 2mm 30min	Vibration Table	Electrically Functional
Cable Tensile Strength Test	Loading Weight 4 kg 60 Seconds Cycling in 24 Hours	Tensile Testing Machine	Electrically Functional	
Electrical	ESD Test	Contact Discharge 2 KV	ESD Testing Machine	Electrically Functional
		Air Discharge 4 KV	ESD Testing Machine	Electrically Functional
	Aging Test	On/Off 30 Seconds Cycling in 24 Hours	Power Switch	Electrically Functional
	USB Connector	On/Off 250 Times	Plug and Unplug	Electrically Functional





Inspection Item		Inspection Method	Standard of Inspection	
Category	Item			
Appearance	FPC/ PCB	Color	The Naked Eye	Major Difference is Not Allowed.
		Be Torn/Chopped	The Naked Eye	Copper Crack Exposure is Not Allowed.
		Marking	The Naked Eye	Clear, Recognizable (Within 30cm Distance)
	Holder	Scratches	The Naked Eye	The Inside Crack Exposure is Not Allowed
		Gap	The Naked Eye	Meet the Height Standard
		Screw	The Naked Eye	Make Sure Screws Are Presented (If Any)
		Damage	The Naked Eye	The Inside Crack Exposure is Not Allowed
	Lens	Scratch	The Naked Eye	No Effect On Resolution Standard
		Contamination	The Naked Eye	No Effect On Resolution Standard
		Oil Film	The Naked Eye	No Effect On Resolution Standard
		Cover Tape	The Naked Eye	No Issue On Appearance.
	Function	Image	No Communication	Test Board
Bright Pixel			Black Board	Not Allowed In the Image Center
Dark Pixel			White board	Not Allowed In the Image Center
Blurry			The Naked Eye	Not Allowed
No Image			The Naked Eye	Not Allowed
Vertical Line			The Naked Eye	Not Allowed
Horizontal Line			The Naked Eye	Not Allowed
Light Leakage			The Naked Eye	Not Allowed
Blinking Image			The Naked Eye	Not Allowed
Bruise			Inspection Jig	Not Allowed
Resolution			Chart	Follows Outgoing Inspection Chart Standard
Color			The Naked Eye	No Issue
Noise			The Naked Eye	Not Allowed
Corner Dark			The Naked Eye	Less Than 100px By 100px
Color Resolution			The Naked Eye	No Issue
Dimension	Height	The Naked Eye	Follows Approval Data Sheet	
	Width	The Naked Eye	Follows Approval Data Sheet	
	Length	The Naked Eye	Follows Approval Data Sheet	
	Overall	The Naked Eye	Follows Approval Data Sheet	



KLT Package Solutions

KLT Camera Module



Complete with Lens Protection Film



Tray with Grid and Space



Place Cameras on the Tray





Camera Modules Package Solution

Full Tray of Cameras



Cover Tray with Lid



Put Tray into Anti-Static Bag



Vacuum the Anti-Static Bag





Camera Modules Package Solution

Sealed Vacuum Bag with Labels

- 1. Model and Description 2. Quantity 3. Shipping Date 4. Caution**





CMOS CAMERA MODULES



your BEST camera module partner

Large Order Package Solution

Place Foam Sheets Between Trays

Foam Sheets are Slightly Larger than Trays



www.KaiLapTech.com

www.KaiLapTech.com

Place Foam Sheets and Trays into Box

Foam Sheets are Tightly Fitting Box



www.KaiLapTech.com sales@KaiLapTech.com Tel: (852) 6908 1256 Fax: (852) 3017 6778

All rights reserved @ Kai Lap Technologies Group Ltd. Specifications subject to change without notice.



CMOS CAMERA MODULES



your BEST camera module partner

Small Order Package Solution

Place Foam Sheets and Trays into Small Box



www.KaiLapTech.com

www.KaiLapTech.com

Package in Small Box for Shipment

Foam Sheets are Nicely Fitting the Small Box



www.KaiLapTech.com

www.KaiLapTech.com

Place Small Boxes into Larger Box



www.KaiLapTech.com



www.KaiLapTech.com



your **BEST** camera module partner

Carbon Box Package Solution

Seal the Carbon Box

Final Package Labelled Box



Carbon Box Ready for Shipment

1. Delivery Address and Phone No.
2. Box No. and Ship Date
3. Fragile Caution





Sample Order Package Solution

Place Sample into Small Anti-Static Bag



Place Connectors into Small Ant-Static Bag



Sample Labels on the Small Bag

1. Camera Module or Connector Model
2. Shipping Date and Quantity
3. Caution





Connectors Large Order Package Solution

Connectors in a Wheel



Label Connectors in the Wheel



The Wheel is Perfectly Fitting the Box



Connectors Box Ready for Shipment



Company Kai Lap Technologies (KLT)

Kai Lap Technologies Group Limited. (KLT) was established in 2009, a next-generation technology driven manufacturer specialized in research, design, and produce of audio and video products. KLT is occupying 20,000 square feet automated plants with 100 employees of annual throughput 30,000,000 units cameras.

KLT provides OEM, ODM design, contract manufacturing, and builds the camera products. You may provide the requirements to us, even with a hand draft, our sales and engineering work together to meet your needs. We consider ourselves your last-term partner in developing practical and innovative solutions.

Our team covers everything from initial concept development to mass produced product. KLT specializes in customized camera design, raw material, electronic engineering, firmware/software development, product testing, and packing design. Our experienced strategic supply systems offer a robust and dependable manufacturing capacity for orders of various sizes.

www.KaiLapTech.com

www.KaiLapTech.com



Limited Warranty

KLT provides the following limited warranty if you purchased the Product(s) directly from KLT company or from KLT's website, www.KaiLapTech.com. Product(s) purchased from other sellers or sources are not covered by this Limited Warranty. KLT guarantees that the Product(s) will be free from defects in materials and workmanship under normal use for a period of one (1) year from the date you receive the product ("Warranty Period").

For all Product(s) that contain or develop material defects in materials or workmanship during the Warranty Period, KLT will, at its sole option, either: (i) repair the Product(s); (ii) replace the Product(s) with a new or refurbished Product(s) (replacement Product(s) being of identical model or functional equivalent); or (iii) provide you a refund of the price you paid for the Product(s).

This Limited Warranty of KLT is solely limited to repair and/or replacement on the terms set forth above. KLT is not reliable or responsible for any subsequent events.





CMOS CAMERA MODULES



your BEST camera module partner

KLT Strength

Powerful Factory



www.KaiLapTech.com

www.KaiLapTech.com

Professional Service



www.KaiLapTech.com

www.KaiLapTech.com

Promised Delivery



www.KaiLapTech.com

www.KaiLapTech.com

www.KaiLapTech.com sales@KaiLapTech.com Tel: (852) 6908 1256 Fax: (852) 3017 6778

All rights reserved @ Kai Lap Technologies Group Ltd. Specifications subject to change without notice.